

PARTS LIST					
ITEM	QTY	PART NO.	PART DESCRIPTION	UNIT WT.	NET WT.
1	1	FACE-ASY1-30132	SINGLE SECTOR FACE MOUNT KIT W/ W/ 2-7/8" X 132" PIPES	700.64	700.64
2	1	FACE-PM496	FACE ASSEMBLY PIPE MOUNT KIT	145.77	145.77
3	2	FSP296-K	FACE STRUT PIPE KIT 2-3/8" X 96"	80.08	160.17
TOTAL WT. #				1020.95	

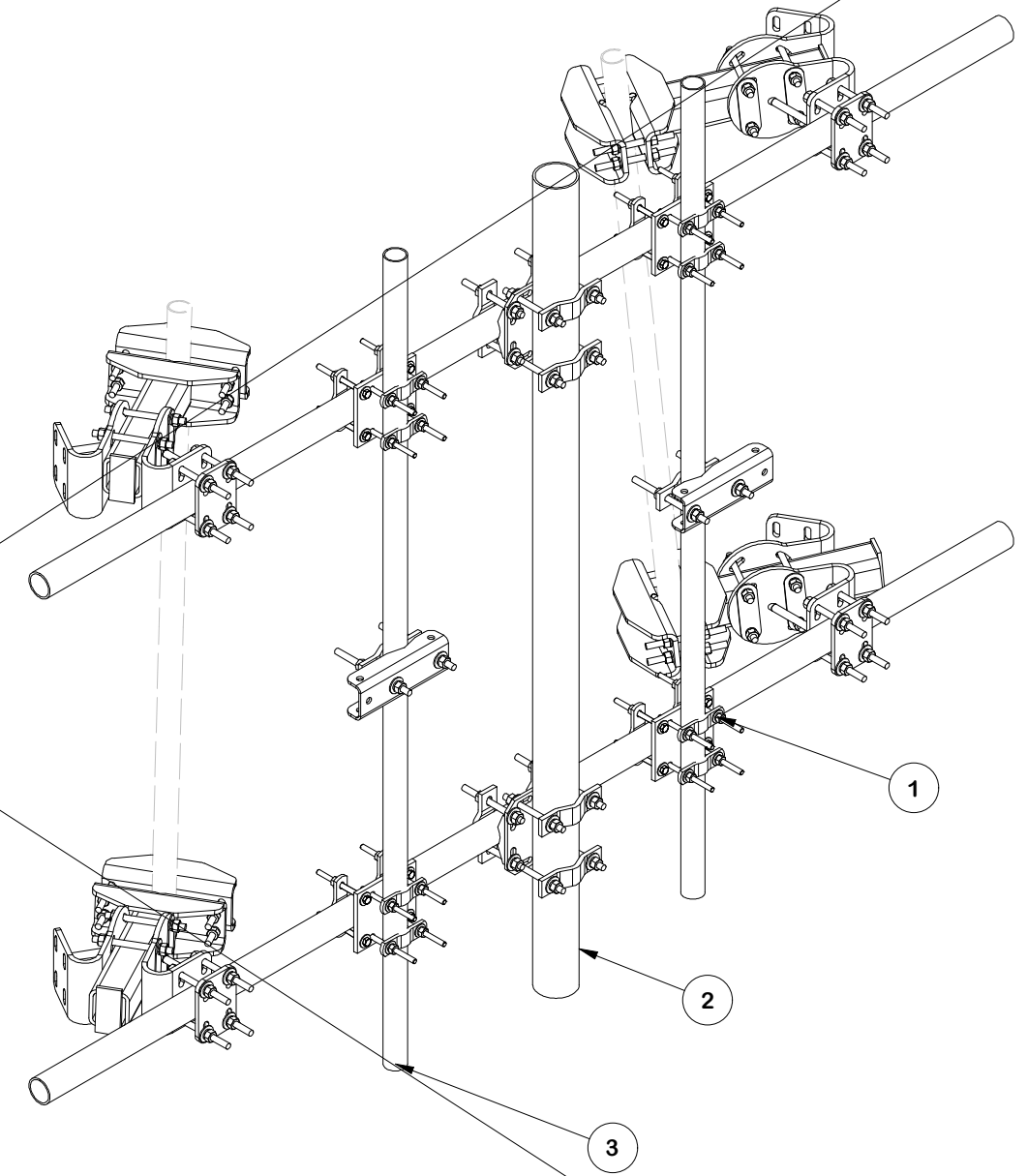
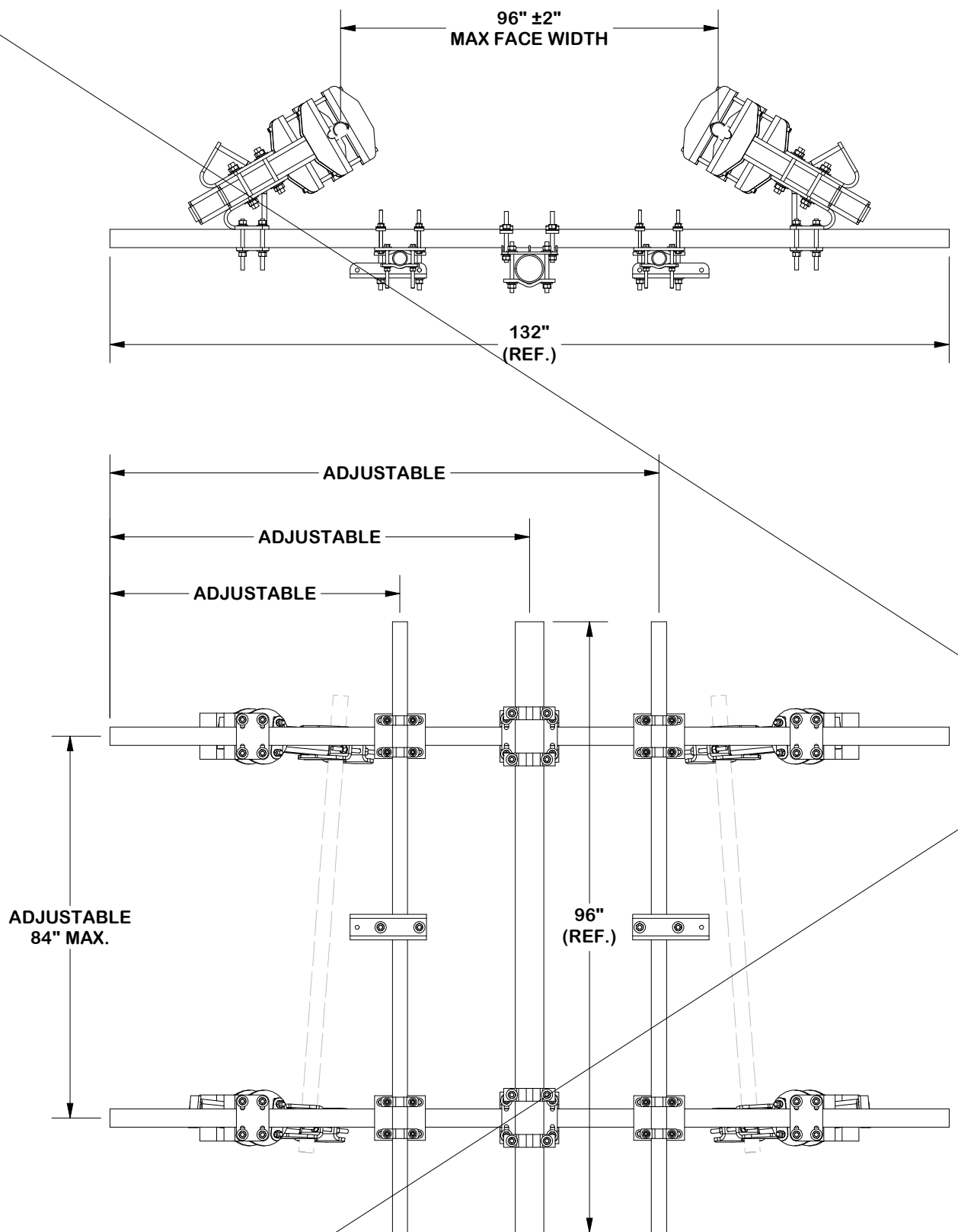

FINISH:
HOT DIP GALVANIZED.

PRELIMINARY DESIGN
DO NOT BUILD

TOLERANCE NOTES

TOLERANCES ON DIMENSIONS, UNLESS OTHERWISE NOTED ARE:
 SAWED, SHEARED AND GAS CUT EDGES ($\pm 0.030"$)
 DRILLED AND GAS CUT HOLES ($\pm 0.030"$) - NO CONING OF HOLES
 LASER CUT EDGES AND HOLES ($\pm 0.010"$) - NO CONING OF HOLES
 BENDS AND ANGLES ARE $\pm 1/2$ DEGREE
 ALL OTHER MACHINING ($\pm 0.030"$)
 ALL OTHER ASSEMBLY ($\pm 0.060"$)

PATENT INFORMATION: WWW.SITEPRO1.COM/PATENTS

PROPRIETARY NOTE:
 THE DATA AND TECHNIQUES CONTAINED IN THIS DRAWING ARE PROPRIETARY INFORMATION OF VALMONT INDUSTRIES AND CONSIDERED A TRADE SECRET. ANY USE OR DISCLOSURE WITHOUT THE CONSENT OF VALMONT INDUSTRIES IS STRICTLY PROHIBITED.

DESCRIPTION
**SINGLE SECTOR MICROWAVE KIT
 W/ 2-7/8" DIA. X 132" HORIZONTALS
 & MOUNT PIPE W/ DUAL STRUTS**

SITE PRO 1
 A valmont COMPANY

Engineering Support Team:
 sp1engineering@valmont.com

CPD NO. SP1	DRAWN BY SDR 2/20/2026	ENG. APPROVAL
CLASS 87	SUB 02	DRAWING USAGE CUSTOMER

PART NO. FMW10-30DS	PAGE 1 OF 9
DWG. NO. FMW10-30DS	

NOTES:

1. THE MAXIMUM TAPER ADJUSTMENT IS 8° BASED UPON 60" SPACING OF ADJUSTABLE MOUNTING BRACKETS.
2. MAX. FACE WIDTH 96" ±2".

PARTS LIST							
ITEM	QTY	PART NO.	BOX NO.	PART DESCRIPTION	LENGTH	UNIT WT.	NET WT.
1	8	FACE-CCHALF	P-FACE-CCHALF	FACE ASSEMBLY CORNER CONNECTION (HALF)		33.15	265.20
2	4	FACE-LC	P-FACE-LC	FACE ASSEMBLY LEG CONNECTION		26.99	107.96
3	4	X-FACE-TW		TUBE WELDMENT		48.02	192.07
4	2	P30132		2-7/8" X 132" (2-1/2" SCH. 40) GALVANIZED PIPE	132 in	67.70	135.41
						TOTAL WT. #	700.64

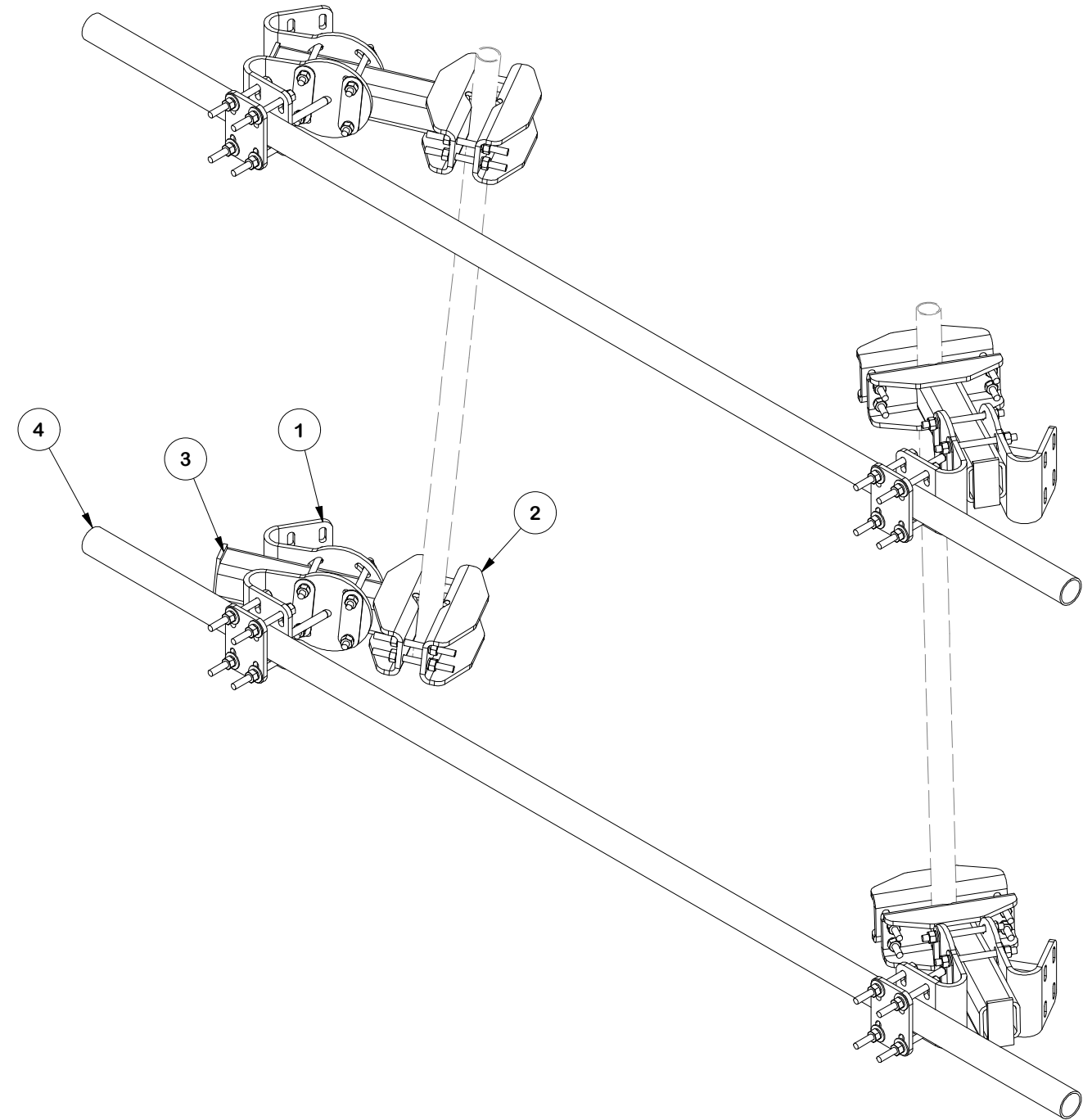
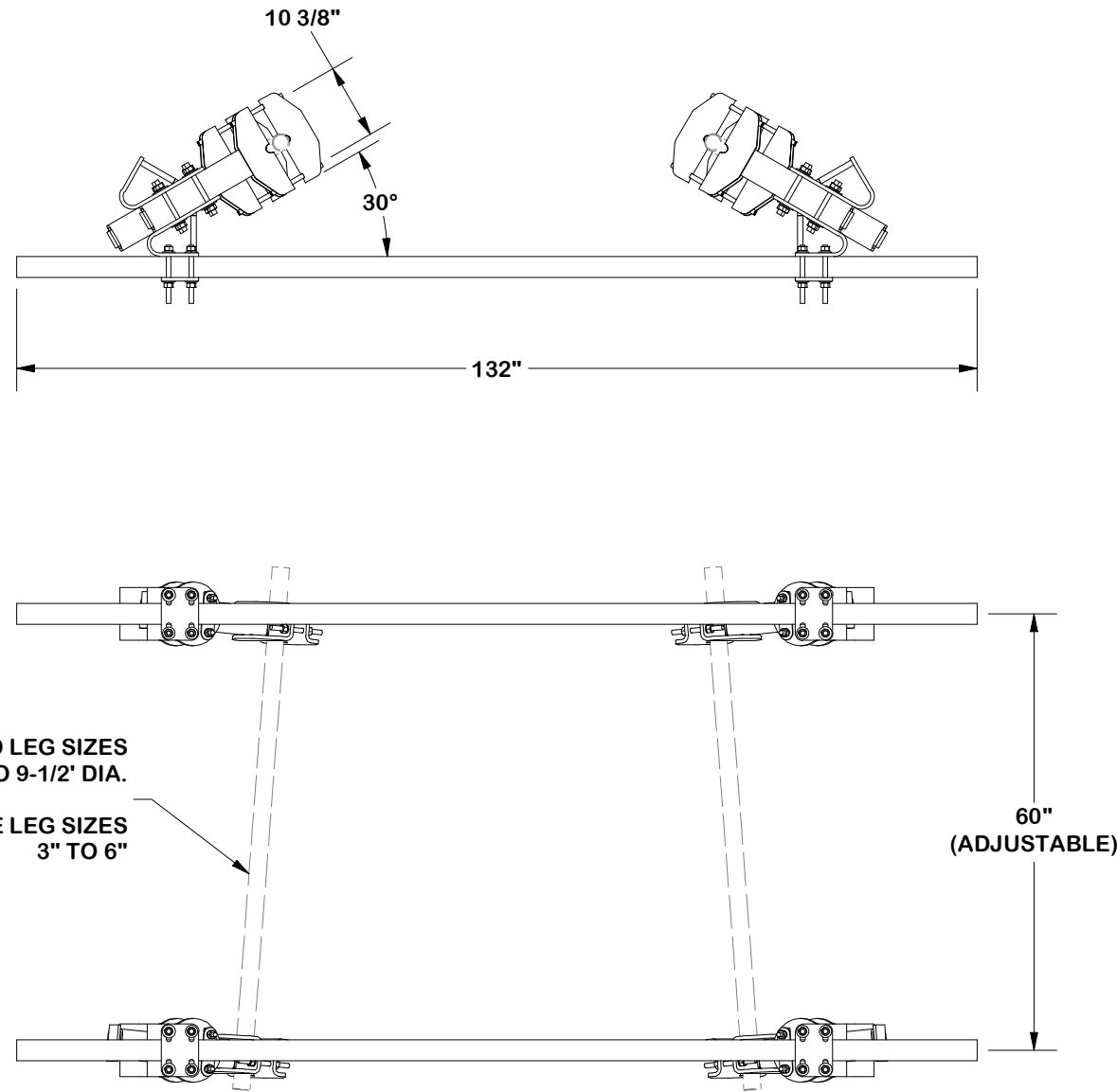

FINISH:
HOT DIP GALVANIZED.

TOLERANCE NOTES

TOLERANCES ON DIMENSIONS, UNLESS OTHERWISE NOTED ARE:
 SAWED, SHEARED AND GAS CUT EDGES ($\pm 0.030"$)
 DRILLED AND GAS CUT HOLES ($\pm 0.030"$) - NO CONING OF HOLES
 LASER CUT EDGES AND HOLES ($\pm 0.010"$) - NO CONING OF HOLES
 BENDS AND ANGLES ARE $\pm 1/2$ DEGREE
 ALL OTHER MACHINING ($\pm 0.030"$)
 ALL OTHER ASSEMBLY ($\pm 0.060"$)

PROPRIETARY NOTE:
 THE DATA AND TECHNIQUES CONTAINED IN THIS DRAWING ARE PROPRIETARY INFORMATION OF VALMONT INDUSTRIES AND CONSIDERED A TRADE SECRET. ANY USE OR DISCLOSURE WITHOUT THE CONSENT OF VALMONT INDUSTRIES IS STRICTLY PROHIBITED.

DESCRIPTION
**SINGLE SECTOR MICROWAVE KIT
 W/ 2-7/8" DIA. X 132" HORIZONTALS
 & MOUNT PIPE W/ DUAL STRUTS**



Engineering Support Team:
 sp1engineering@valmont.com

REV	DESCRIPTION OF REVISIONS	CPD	BY	DATE
B	REVISED DRAWING TO SINGLE ASSEMBLY	SP1	ADB	11/18/2025
A	ADDED VIEWS FOR CLARITY	SP1	ADB	9/16/2025
REVISION HISTORY				

PATENT INFORMATION: WWW.SITEPRO1.COM/PATENTS

CPD NO. SP1	DRAWN BY SDR 2/20/2026	ENG. APPROVAL
CLASS 87	SUB 02	DRAWING USAGE CUSTOMER
CHECKED BY		

PART NO. FACE-ASY1-30132	2 OF 9 PAGE
DWG. NO. FMW10-30DS	

PARTS LIST						
ITEM	QTY	PART NO.	PART DESCRIPTION	LENGTH	UNIT WT.	NET WT.
1	1	X-FACE-TA	TAPER ADJUSTMENT WELDMENT		20.84	20.84
2	1	X-FACE-CP	CONNECTION PLATE	12 in	4.80	4.80
3	2	X-FACE-SB	SPACER BRACKET (WASHER)	6 3/4 in	0.45	0.90
4	6	G58R-8	5/8" x 8" THREADED ROD (HDG.)		0.70	4.18
5	8	G58FW	5/8" HDG USS FLATWASHER	1/8 in	0.07	0.56
6	12	G58LW	5/8" HDG LOCKWASHER		0.03	0.31
7	12	G58NUT	5/8" HDG HEAVY 2H HEX NUT		0.13	1.56
					TOTAL WT. #	33.15

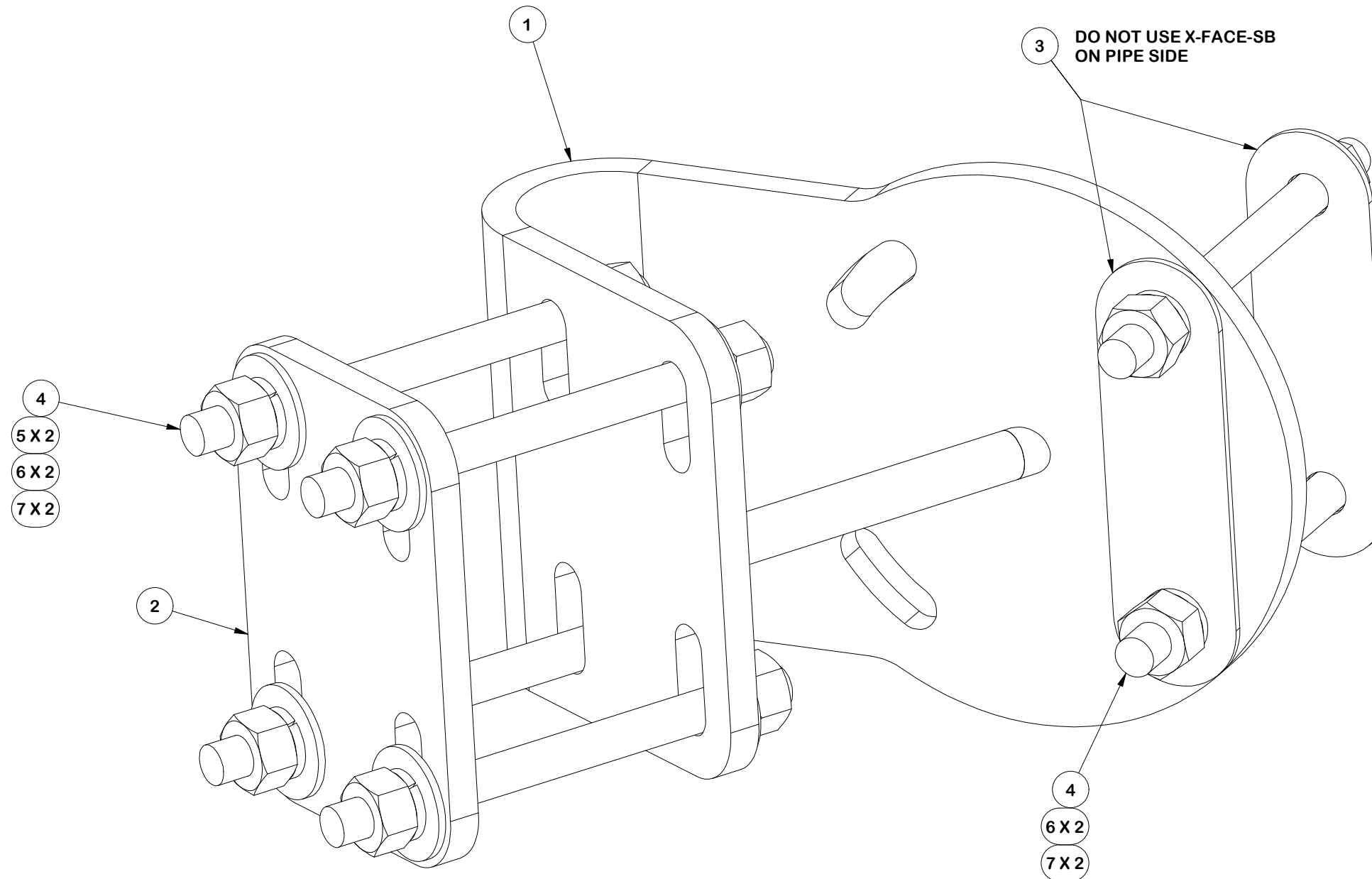

FINISH:
HOT DIP GALVANIZED.

TOLERANCE NOTES

TOLERANCES ON DIMENSIONS, UNLESS OTHERWISE NOTED ARE:
 SAWED, SHEARED AND GAS CUT EDGES ($\pm 0.030"$)
 DRILLED AND GAS CUT HOLES ($\pm 0.030"$) - NO CONING OF HOLES
 LASER CUT EDGES AND HOLES ($\pm 0.010"$) - NO CONING OF HOLES
 BENDS AND ANGLES ARE $\pm 1/2$ DEGREE
 ALL OTHER MACHINING ($\pm 0.030"$)
 ALL OTHER ASSEMBLY ($\pm 0.060"$)

PATENT INFORMATION: WWW.SITEPRO1.COM/PATENTS

PROPRIETARY NOTE:
 THE DATA AND TECHNIQUES CONTAINED IN THIS DRAWING ARE PROPRIETARY INFORMATION OF VALMONT INDUSTRIES AND CONSIDERED A TRADE SECRET. ANY USE OR DISCLOSURE WITHOUT THE CONSENT OF VALMONT INDUSTRIES IS STRICTLY PROHIBITED.

DESCRIPTION
**SINGLE SECTOR MICROWAVE KIT
 W/ 2-7/8" DIA. X 132" HORIZONTALS
 & MOUNT PIPE W/ DUAL STRUTS**

CPD NO. SP1	DRAWN BY SDR 2/20/2026	ENG. APPROVAL
CLASS 87	SUB 02	DRAWING USAGE CUSTOMER
CHECKED BY		



A valmont COMPANY

Engineering Support Team:
 sp1engineering@valmont.com

PART NO. FACE-CCHALF
DWG. NO. FMW10-30DS

PARTS LIST						
ITEM	QTY	PART NO.	PART DESCRIPTION	LENGTH	UNIT WT.	NET WT.
1	1	X-FACE-BP	BENT PLATE FOR X-HDCAMTBW	13 in	18.08	18.08
2	4	G58R-14	5/8" x 14" THREADED ROD (HDG.)		1.22	4.88
3	4	G58R-8	5/8" x 8" THREADED ROD (HDG.)		0.70	2.79
4	8	G58LW	5/8" HDG LOCKWASHER		0.03	0.21
5	8	G58NUT	5/8" HDG HEAVY 2H HEX NUT		0.13	1.04
					TOTAL WT. #	26.99

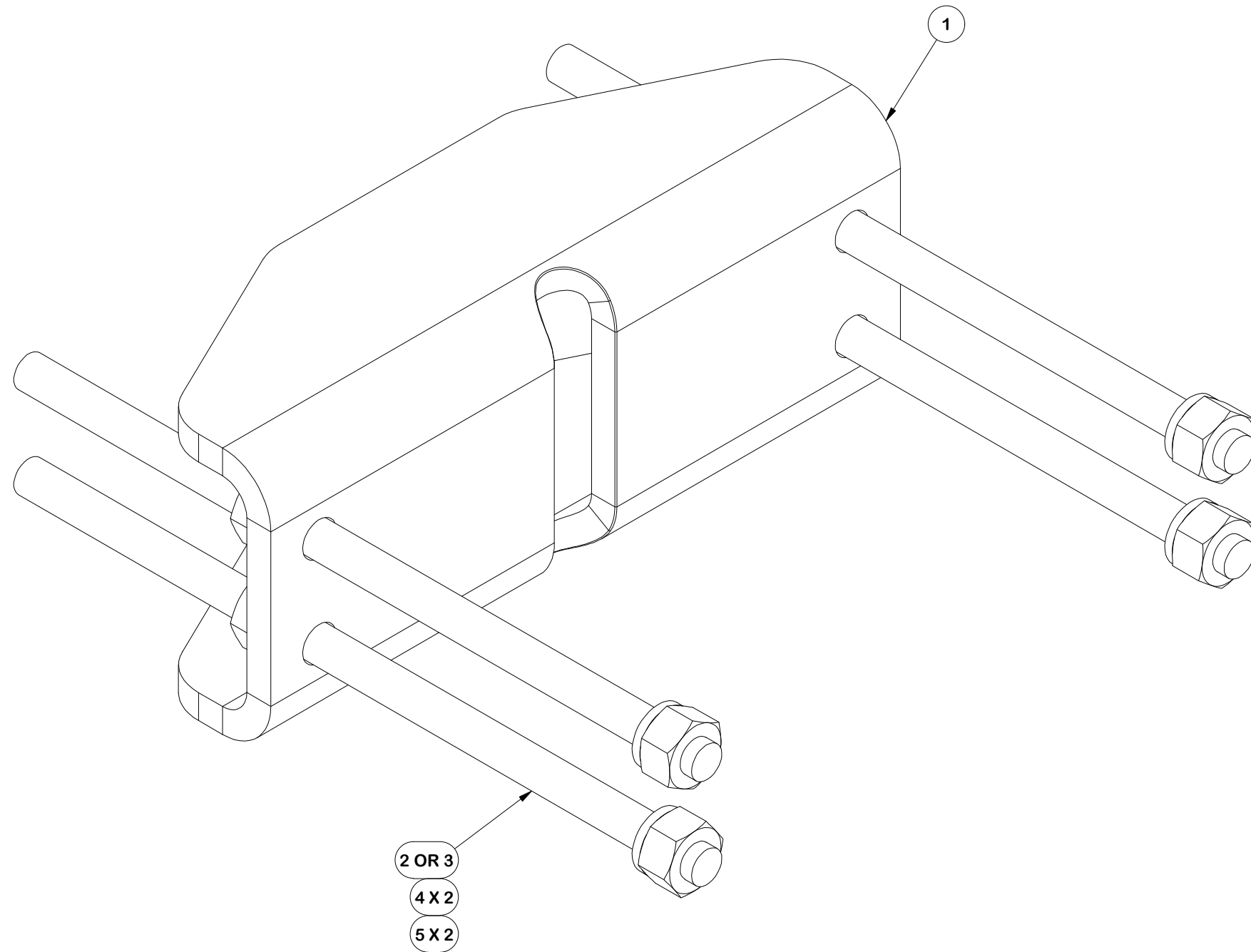

FINISH:
HOT DIP GALVANIZED.

TOLERANCE NOTES

TOLERANCES ON DIMENSIONS, UNLESS OTHERWISE NOTED ARE:
 SAWED, SHEARED AND GAS CUT EDGES ($\pm 0.030"$)
 DRILLED AND GAS CUT HOLES ($\pm 0.030"$) - NO CONING OF HOLES
 LASER CUT EDGES AND HOLES ($\pm 0.010"$) - NO CONING OF HOLES
 BENDS AND ANGLES ARE $\pm 1/2$ DEGREE
 ALL OTHER MACHINING ($\pm 0.030"$)
 ALL OTHER ASSEMBLY ($\pm 0.060"$)

PATENT INFORMATION: WWW.SITEPRO1.COM/PATENTS

PROPRIETARY NOTE:
 THE DATA AND TECHNIQUES CONTAINED IN THIS DRAWING ARE PROPRIETARY INFORMATION OF VALMONT INDUSTRIES AND CONSIDERED A TRADE SECRET. ANY USE OR DISCLOSURE WITHOUT THE CONSENT OF VALMONT INDUSTRIES IS STRICTLY PROHIBITED.

DESCRIPTION
**SINGLE SECTOR MICROWAVE KIT
 W/ 2-7/8" DIA. X 132" HORIZONTALS
 & MOUNT PIPE W/ DUAL STRUTS**

CPD NO. SP1	DRAWN BY SDR 2/20/2026	ENG. APPROVAL
CLASS 87	SUB 02	DRAWING USAGE CUSTOMER
CHECKED BY		



Engineering Support Team:
 sp1engineering@valmont.com

PART NO. FACE-LC	PAGE 4 OF 9
DWG. NO. FMW10-30DS	

PARTS LIST							
ITEM	QTY	PART NO.	BOX NO.	PART DESCRIPTION	LENGTH	UNIT WT.	NET WT.
1	1	P496		4-1/2" X 96" SCH. 40 GALVANIZED PIPE	96 in	91.60	91.60
2	2	FCX45-U	P-FCX45-U	HEAVY-DUTY UNIVERSAL CROSSOVER KIT		27.08	54.17
						TOTAL WT. #	145.77

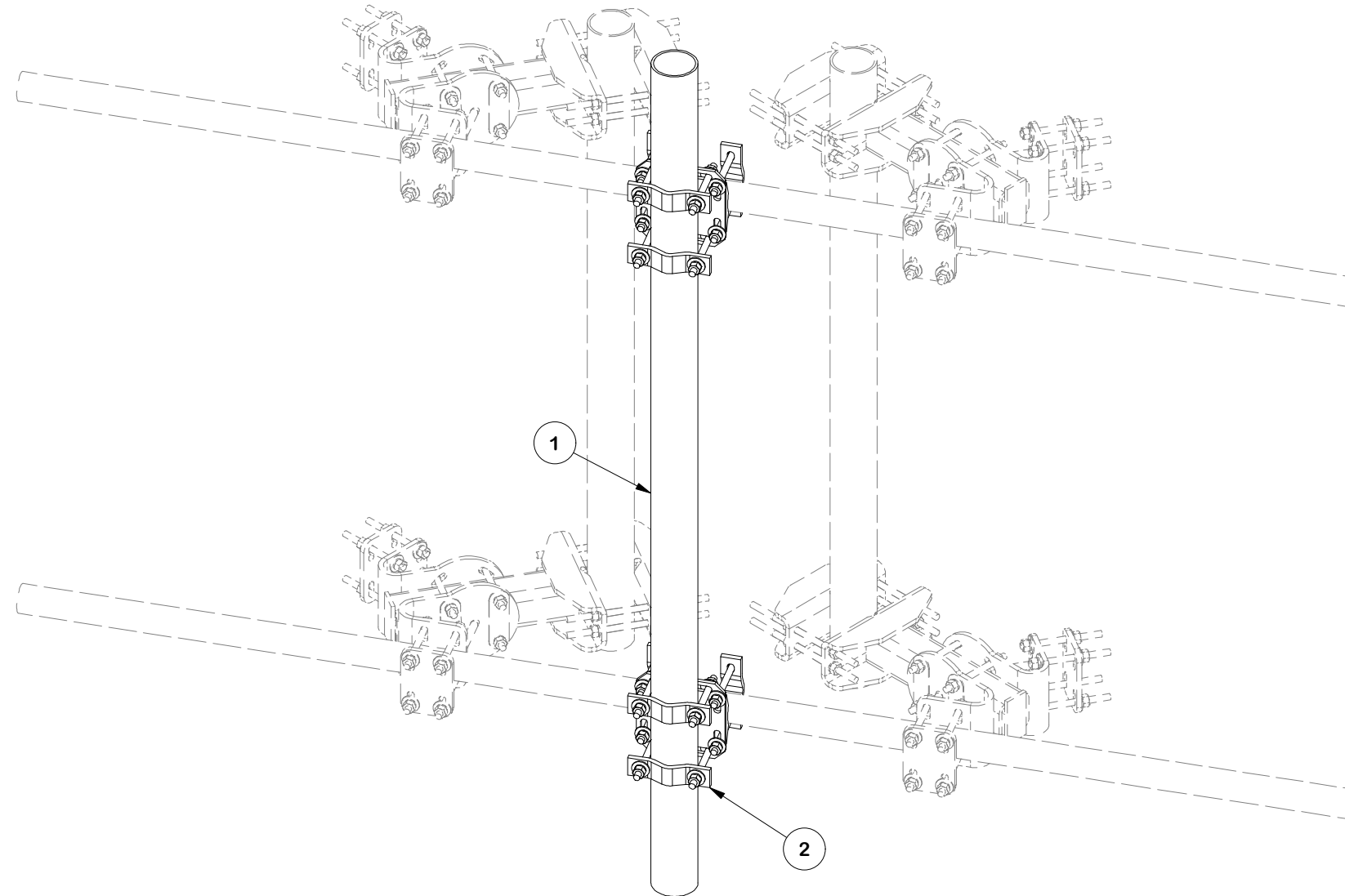

FINISH:
HOT DIP GALVANIZED.

TOLERANCE NOTES

TOLERANCES ON DIMENSIONS, UNLESS OTHERWISE NOTED ARE:
 SAWED, SHEARED AND GAS CUT EDGES ($\pm 0.030"$)
 DRILLED AND GAS CUT HOLES ($\pm 0.030"$) - NO CONING OF HOLES
 LASER CUT EDGES AND HOLES ($\pm 0.010"$) - NO CONING OF HOLES
 BENDS AND ANGLES ARE $\pm 1/2$ DEGREE
 ALL OTHER MACHINING ($\pm 0.030"$)
 ALL OTHER ASSEMBLY ($\pm 0.060"$)

PATENT INFORMATION: WWW.SITEPRO1.COM/PATENTS

PROPRIETARY NOTE:
 THE DATA AND TECHNIQUES CONTAINED IN THIS DRAWING ARE PROPRIETARY INFORMATION OF VALMONT INDUSTRIES AND CONSIDERED A TRADE SECRET. ANY USE OR DISCLOSURE WITHOUT THE CONSENT OF VALMONT INDUSTRIES IS STRICTLY PROHIBITED.

DESCRIPTION
**SINGLE SECTOR MICROWAVE KIT
 W/ 2-7/8" DIA. X 132" HORIZONTALS
 & MOUNT PIPE W/ DUAL STRUTS**

CPD NO. SP1	DRAWN BY SDR 2/20/2026	ENG. APPROVAL
CLASS 87	SUB 02	DRAWING USAGE CUSTOMER
CHECKED BY		



Engineering
 Support Team:
 sp1engineering@valmont.com

PART NO. FACE-PM496	PAGE 5 OF 9
DWG. NO. FMW10-30DS	

PARTS LIST						
ITEM	QTY	PART NO.	PART DESCRIPTION	LENGTH	UNIT WT.	NET WT.
1	1	X-SCX4-FR	4-1/2" FORTRESS CROSSOVER PLATE		8.10	8.10
2	4	DCP	1/2" THICK, 5-3/4" CNTR TO CENTER CLAMP HALF	8 1/8 in	2.36	9.45
3	8	G5807	5/8" x 7" HDG HEX BOLT GR5 FULL THREAD	7 in	0.70	5.64
4	16	G58FW	5/8" HDG USS FLATWASHER	1/8 in	0.07	1.13
5	8	G58LW	5/8" HDG LOCKWASHER		0.03	0.21
6	8	G58NUT	5/8" HDG HEAVY 2H HEX NUT		0.13	1.04
					TOTAL WT. #	25.62

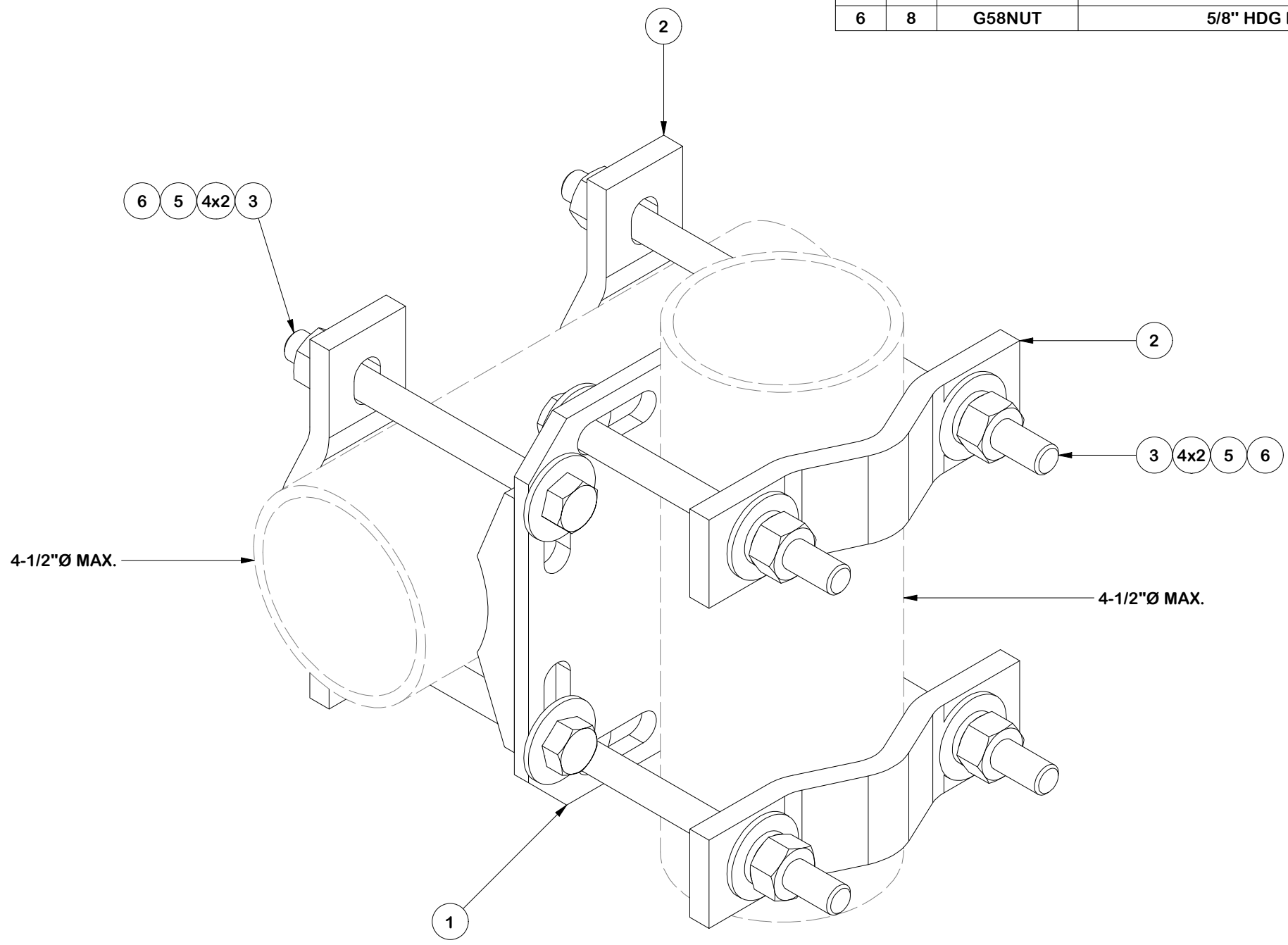

FINISH:
HOT DIP GALVANIZED.

TOLERANCE NOTES

TOLERANCES ON DIMENSIONS, UNLESS OTHERWISE NOTED ARE:
 SAWED, SHEARED AND GAS CUT EDGES ($\pm 0.030"$)
 DRILLED AND GAS CUT HOLES ($\pm 0.030"$) - NO CONING OF HOLES
 LASER CUT EDGES AND HOLES ($\pm 0.010"$) - NO CONING OF HOLES
 BENDS AND ANGLES ARE $\pm 1/2$ DEGREE
 ALL OTHER MACHINING ($\pm 0.030"$)
 ALL OTHER ASSEMBLY ($\pm 0.060"$)

PATENT INFORMATION: WWW.SITEPRO1.COM/PATENTS

PROPRIETARY NOTE:
 THE DATA AND TECHNIQUES CONTAINED IN THIS DRAWING ARE PROPRIETARY INFORMATION OF VALMONT INDUSTRIES AND CONSIDERED A TRADE SECRET. ANY USE OR DISCLOSURE WITHOUT THE CONSENT OF VALMONT INDUSTRIES IS STRICTLY PROHIBITED.

DESCRIPTION
**SINGLE SECTOR MICROWAVE KIT
 W/ 2-7/8" DIA. X 132" HORIZONTALS
 & MOUNT PIPE W/ DUAL STRUTS**

CPD NO. SP1	DRAWN BY SDR 2/20/2026	ENG. APPROVAL
CLASS 87	SUB 02	DRAWING USAGE CUSTOMER
CHECKED BY		

SITE PRO 1
 A valmont COMPANY

Engineering Support Team:
 sp1engineering@valmont.com

PART NO. FCX45-U	PAGE 6 OF 9
DWG. NO. FMW10-30DS	

PARTS LIST									
ITEM	QTY	PART NO.	BOX NO.	PART DESCRIPTION	LENGTH	UNIT WT.	NET WT.		
1	1	P296		2-3/8" X 96" SCH. 40 HDG PIPE (A53 Gr.B Fy=35 ksi min.)	96 in	32.60	32.60		
2	2	SCX7-U	P-SCX7-U	UNIVERSAL CROSSOVER PLATE KIT		17.94	35.88		
3	1	MSS-U		UNIVERSAL MICROWAVE STRUT SUPPORT		11.60	11.60		
						TOTAL WT. #	92.64		

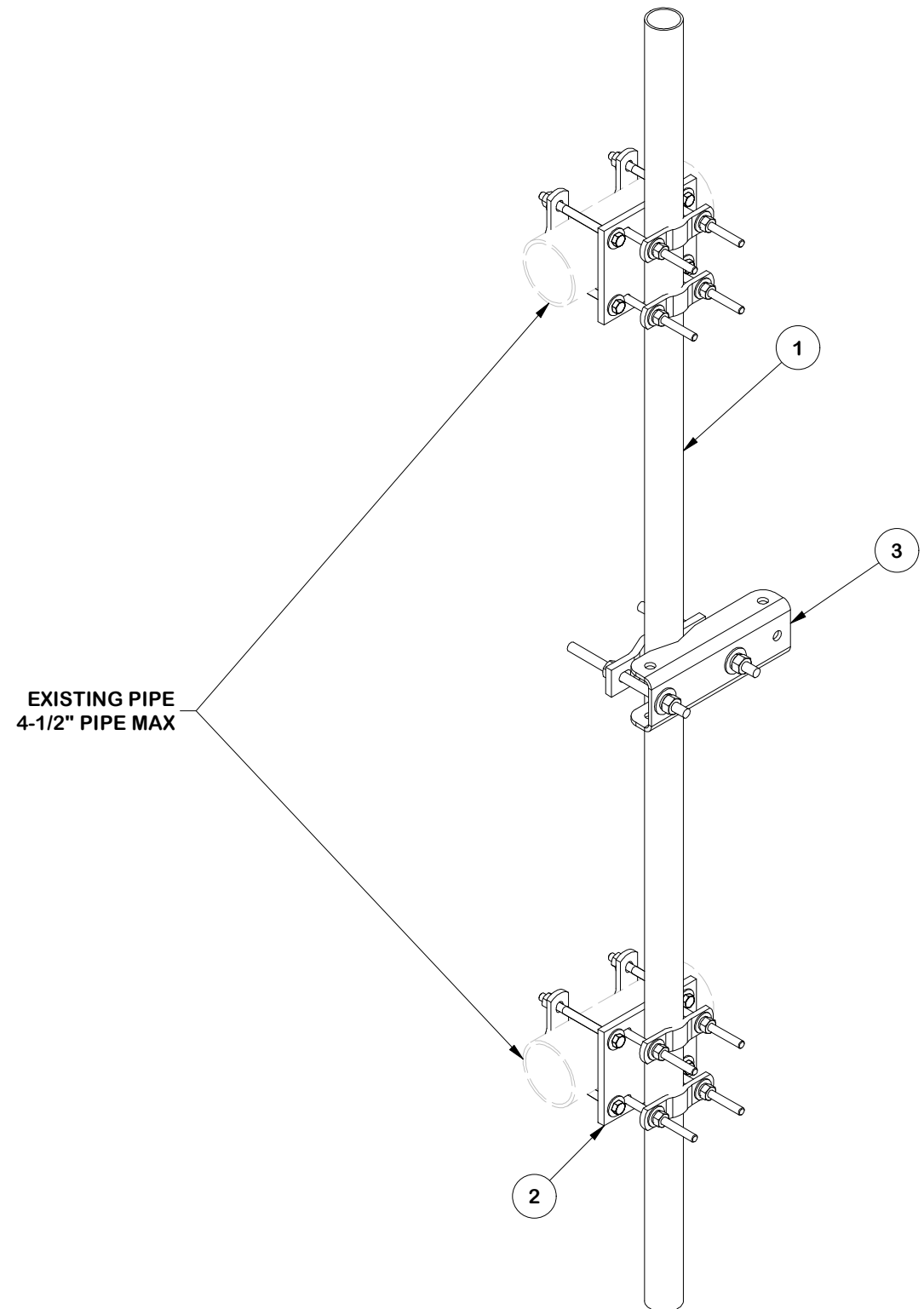

FINISH:
HOT DIP GALVANIZED.

TOLERANCE NOTES

TOLERANCES ON DIMENSIONS, UNLESS OTHERWISE NOTED ARE:
 SAWED, SHEARED AND GAS CUT EDGES ($\pm 0.030"$)
 DRILLED AND GAS CUT HOLES ($\pm 0.030"$) - NO CONING OF HOLES
 LASER CUT EDGES AND HOLES ($\pm 0.010"$) - NO CONING OF HOLES
 BENDS AND ANGLES ARE $\pm 1/2$ DEGREE
 ALL OTHER MACHINING ($\pm 0.030"$)
 ALL OTHER ASSEMBLY ($\pm 0.060"$)

PATENT INFORMATION: WWW.SITEPRO1.COM/PATENTS

PROPRIETARY NOTE:
 THE DATA AND TECHNIQUES CONTAINED IN THIS DRAWING ARE PROPRIETARY INFORMATION OF VALMONT INDUSTRIES AND CONSIDERED A TRADE SECRET. ANY USE OR DISCLOSURE WITHOUT THE CONSENT OF VALMONT INDUSTRIES IS STRICTLY PROHIBITED.

DESCRIPTION
**SINGLE SECTOR MICROWAVE KIT
 W/ 2-7/8" DIA. X 132" HORIZONTALS
 & MOUNT PIPE W/ DUAL STRUTS**

CPD NO.	DRAWN BY	ENG. APPROVAL
SP1	SDR 2/20/2026	
CLASS	SUB	DRAWING USAGE
87	02	CUSTOMER
CHECKED BY		



Engineering Support Team:
 sp1engineering@valmont.com

A valmont COMPANY

PART NO.	FSP296-K
DWG. NO.	FMW10-30DS

PARTS LIST						
ITEM	QTY	PART NO.	PART DESCRIPTION	LENGTH	UNIT WT.	NET WT.
1	1	SCX7	CROSSOVER PLATE	8 in	8.00	8.00
2	2	X-115765	5" V-CLAMP	7 1/16 in	1.09	2.17
3	2	X-100064	CLAMP (4" V-CLAMP) GALVANIZED	6 in	0.92	1.84
4	8	G12065	1/2" x 6-1/2" HDG HEX BOLT GR5 FULL THREAD	6 1/2 in	0.41	3.28
5	4	G12045	1/2" x 4.5" HDG HEX BOLT GR5 FULL THREAD	4 1/2 in	0.30	1.19
6	20	G12FW	1/2" HDG USS FLATWASHER	3/32 in	0.03	0.68
7	9	G12LW	1/2" HDG LOCKWASHER	1/8 in	0.01	0.13
8	9	G12NUT	1/2" HDG HEAVY 2H HEX NUT	7/8 in	0.07	0.64
					TOTAL WT. #	17.94

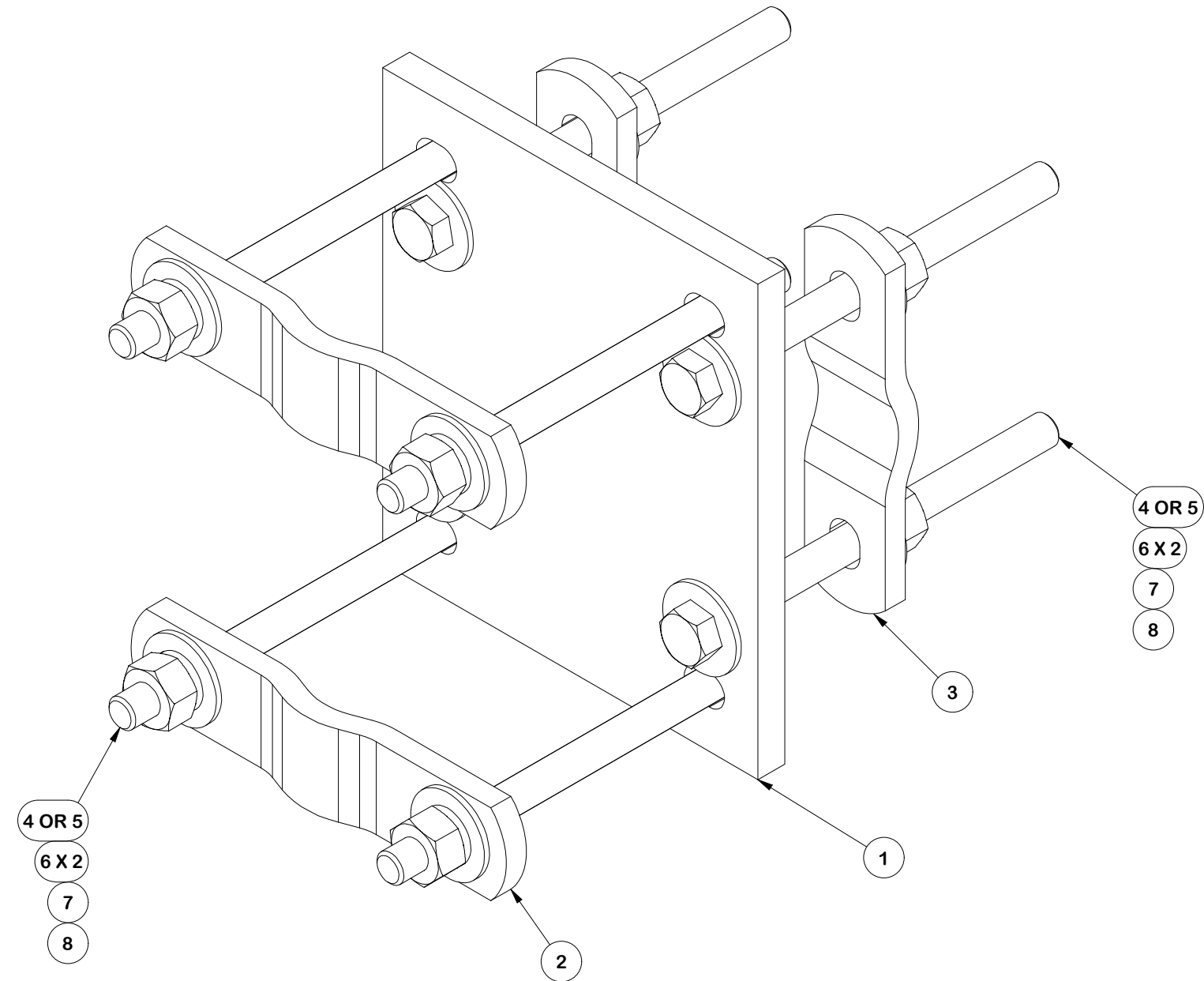

FINISH:
HOT DIP GALVANIZED.

TOLERANCE NOTES

TOLERANCES ON DIMENSIONS, UNLESS OTHERWISE NOTED ARE:
 SAWED, SHEARED AND GAS CUT EDGES ($\pm 0.030"$)
 DRILLED AND GAS CUT HOLES ($\pm 0.030"$) - NO CONING OF HOLES
 LASER CUT EDGES AND HOLES ($\pm 0.010"$) - NO CONING OF HOLES
 BENDS AND ANGLES ARE $\pm 1/2$ DEGREE
 ALL OTHER MACHINING ($\pm 0.030"$)
 ALL OTHER ASSEMBLY ($\pm 0.060"$)

PATENT INFORMATION: WWW.SITEPRO1.COM/PATENTS

PROPRIETARY NOTE:
 THE DATA AND TECHNIQUES CONTAINED IN THIS DRAWING ARE PROPRIETARY INFORMATION OF VALMONT INDUSTRIES AND CONSIDERED A TRADE SECRET. ANY USE OR DISCLOSURE WITHOUT THE CONSENT OF VALMONT INDUSTRIES IS STRICTLY PROHIBITED.

DESCRIPTION
**SINGLE SECTOR MICROWAVE KIT
 W/ 2-7/8" DIA. X 132" HORIZONTALS
 & MOUNT PIPE W/ DUAL STRUTS**

CPD NO.	DRAWN BY	ENG. APPROVAL
SP1	SDR 2/20/2026	
CLASS	DRAWING USAGE	CHECKED BY
87	CUSTOMER	



Engineering Support Team:
 sp1engineering@valmont.com

PART NO.	SCX7-U
DWG. NO.	FMW10-30DS

PARTS LIST						
ITEM	QTY	PART NO.	PART DESCRIPTION	LENGTH	UNIT WT.	NET WT.
1	1	X-MSS-BPL	MICROWAVE STRUT SUPPORT BENT PLATE	12 in	6.59	6.59
2	1	DCP	1/2" THICK, 5-3/4" CNTR TO CENTER CLAMP HALF	8 1/8 in	2.36	2.36
3	2	G58R-10	5/8" x 10" THREADED ROD (HDG.)		0.87	1.74
4	4	G58FW	5/8" HDG USS FLATWASHER	1/8 in	0.07	0.28
5	4	G58LW	5/8" HDG LOCKWASHER		0.03	0.10
6	4	G58NUT	5/8" HDG HEAVY 2H HEX NUT		0.13	0.52
					TOTAL WT. #	11.60

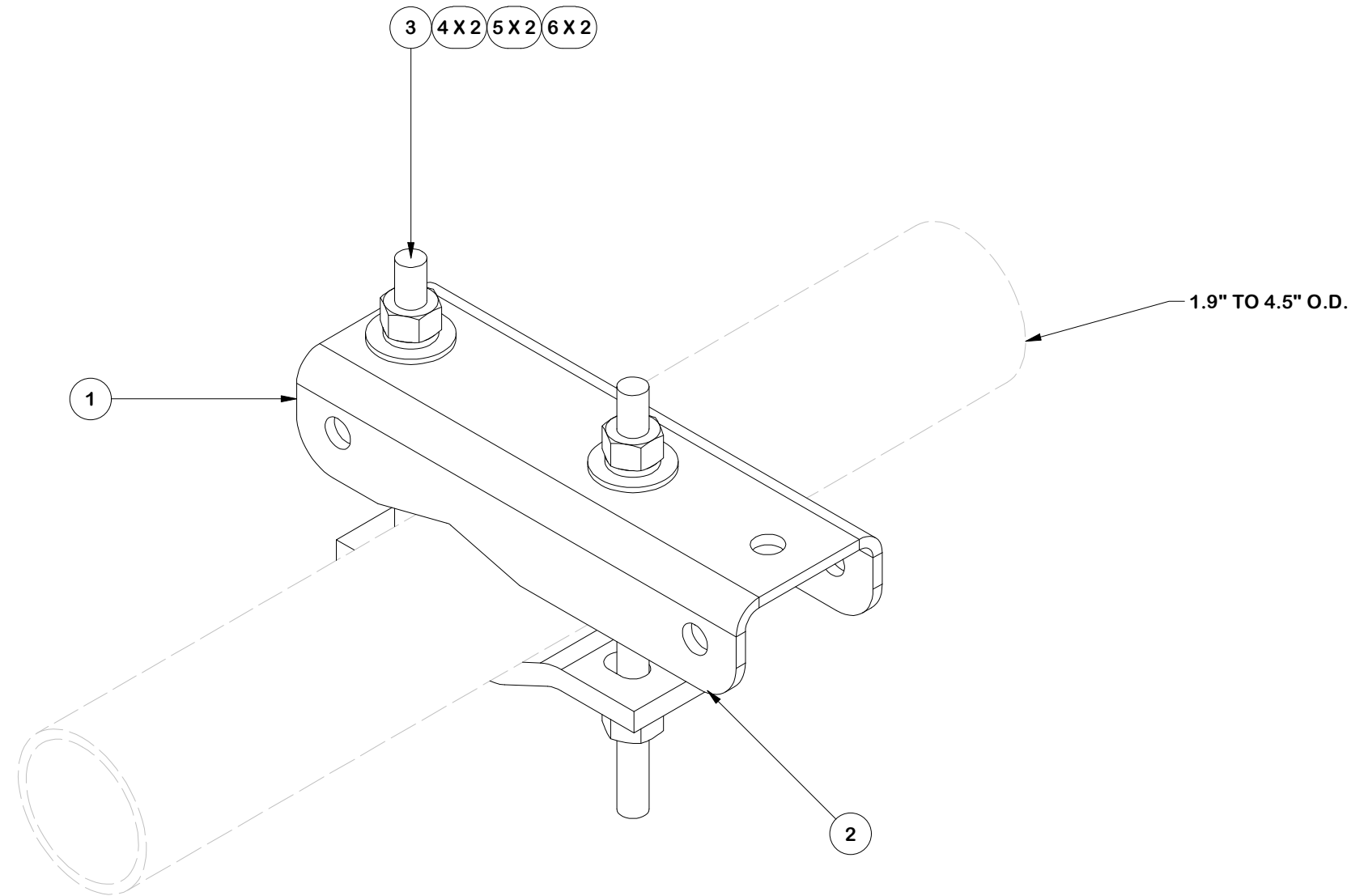

FINISH:
HOT DIP GALVANIZED.

TOLERANCE NOTES

TOLERANCES ON DIMENSIONS, UNLESS OTHERWISE NOTED ARE:
 SAWED, SHEARED AND GAS CUT EDGES ($\pm 0.030"$)
 DRILLED AND GAS CUT HOLES ($\pm 0.030"$) - NO CONING OF HOLES
 LASER CUT EDGES AND HOLES ($\pm 0.010"$) - NO CONING OF HOLES
 BENDS AND ANGLES ARE $\pm 1/2$ DEGREE
 ALL OTHER MACHINING ($\pm 0.030"$)
 ALL OTHER ASSEMBLY ($\pm 0.060"$)

PATENT INFORMATION: WWW.SITEPRO1.COM/PATENTS

PROPRIETARY NOTE:
 THE DATA AND TECHNIQUES CONTAINED IN THIS DRAWING ARE PROPRIETARY INFORMATION OF VALMONT INDUSTRIES AND CONSIDERED A TRADE SECRET. ANY USE OR DISCLOSURE WITHOUT THE CONSENT OF VALMONT INDUSTRIES IS STRICTLY PROHIBITED.

DESCRIPTION
**SINGLE SECTOR MICROWAVE KIT
 W/ 2-7/8" DIA. X 132" HORIZONTALS
 & MOUNT PIPE W/ DUAL STRUTS**



Engineering
 Support Team:
 sp1engineering@valmont.com

A valmont COMPANY

CPD NO. **SP1** DRAWN BY **SDR** 2/20/2026 ENG. APPROVAL

CLASS **87** SUB **02** DRAWING USAGE **CUSTOMER** CHECKED BY

PART NO. **MSS-U**

DWG. NO. **FMW10-30DS**